



**METALLURGICA
LEDRENSE** SOC.COOP.



CATALOG LIST OF PIECES

LONG SIDE PANELS

HEAD PANELS

BOTTOM PANELS

COVER PANELS

PYLONS

ASSEMBLY PLAN:



100 x 25 x 50 cm

100 x 25 x 100 cm

200 x 25 x 50 cm

200 x 25 x 100 cm

positioning of the pylons



LONG SIDE PANELS

DESCRIPTION:

single wire
zinc-aluminum alloy
diameter 6 mm
mesh 19 x 200 mm

cod. L1.05

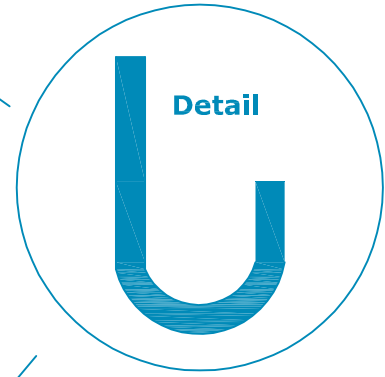
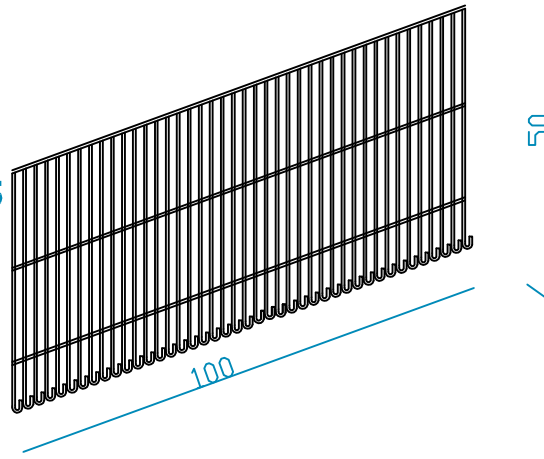

cod. L2.05

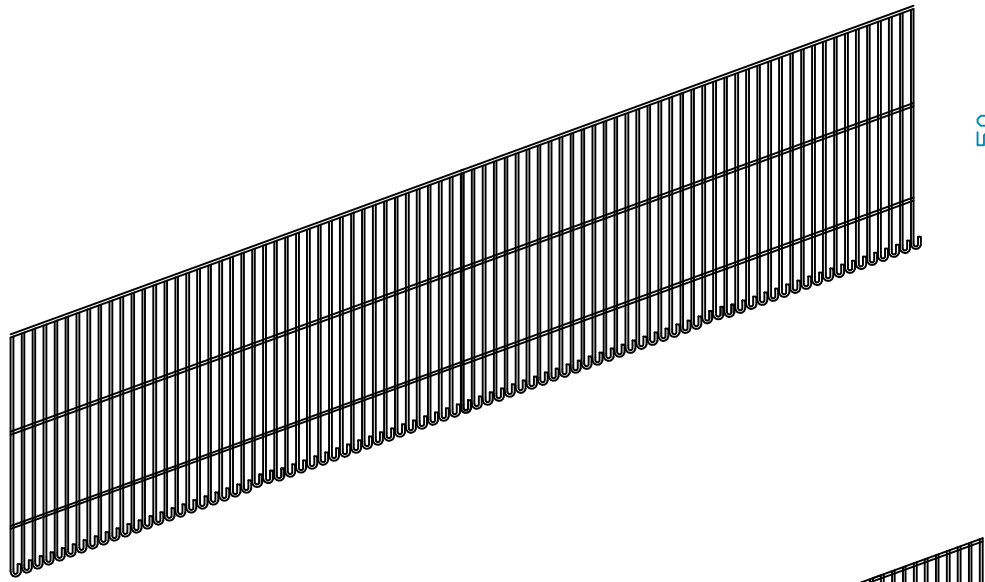

cod. L1

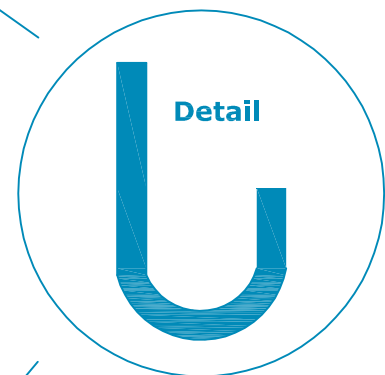
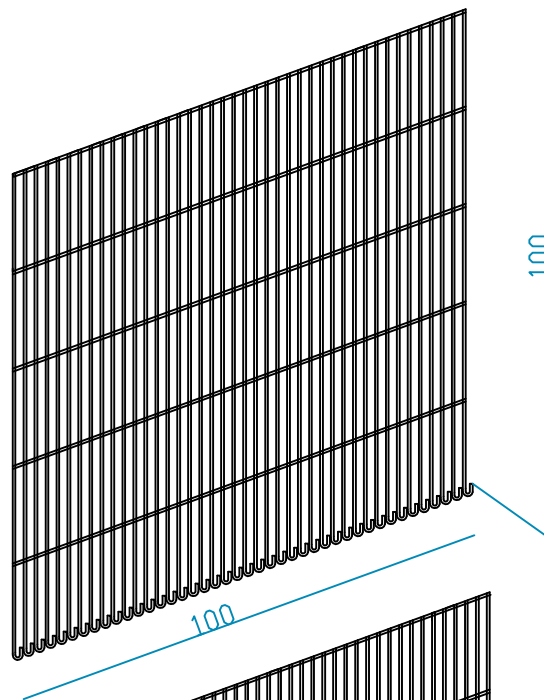

cod. L2

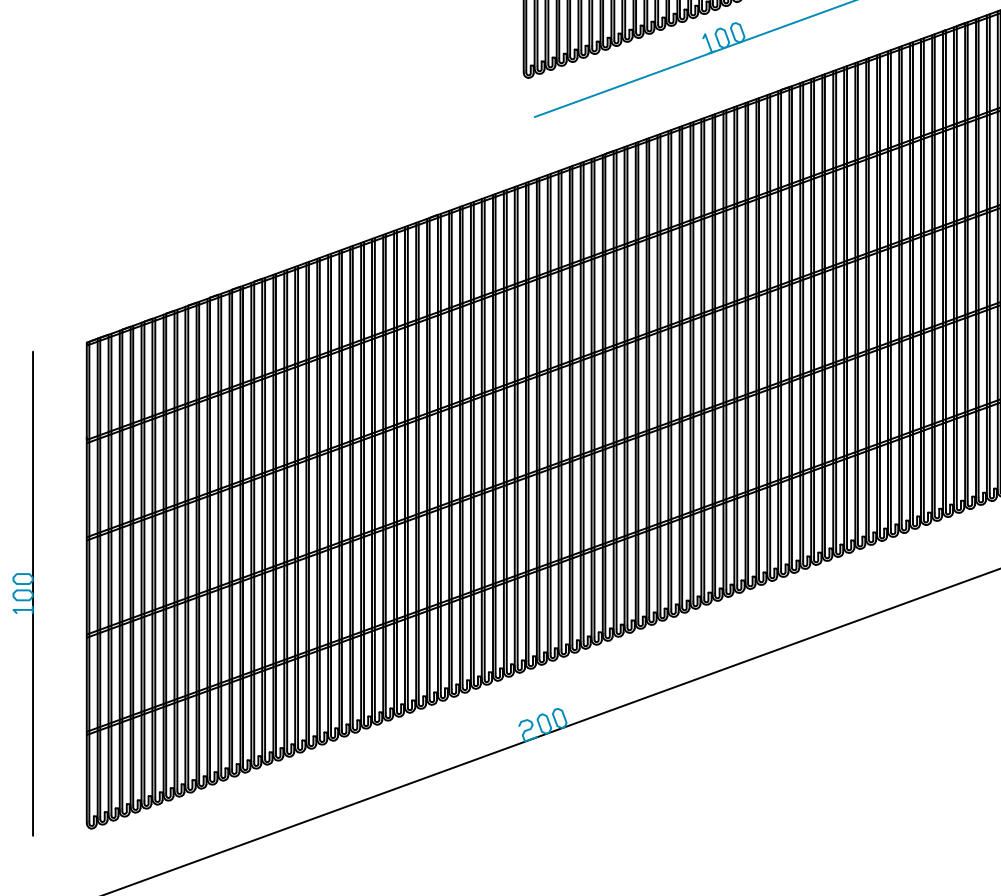

PATENTED

HEAD PANELS

cod. T1.05

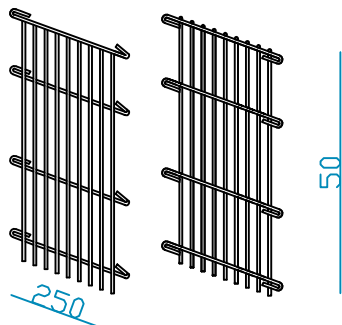

DESCRIPTION:

single wire
zinc-aluminum alloy
diameter 6 mm
mesh 19 x 200 mm

cod. T1

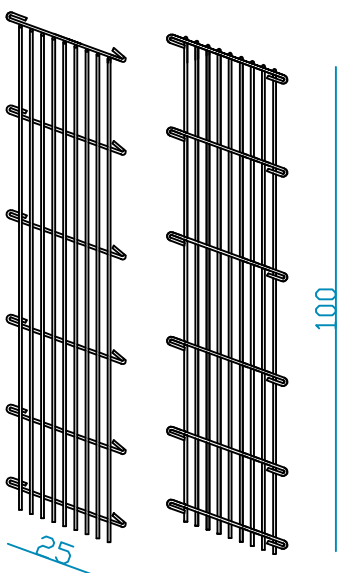

cod. T2.05

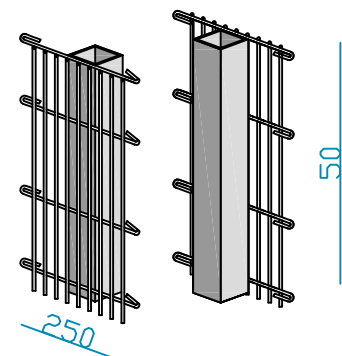

DESCRIPTION:

galvanized pole 60 x 60 mm
thickness 3 mm

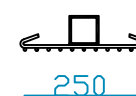
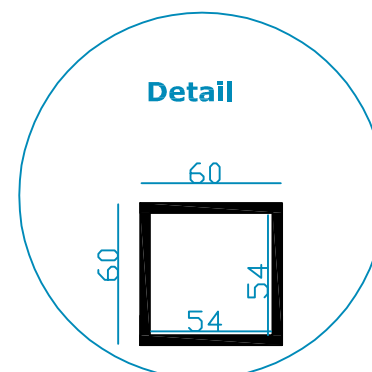

cod. T2

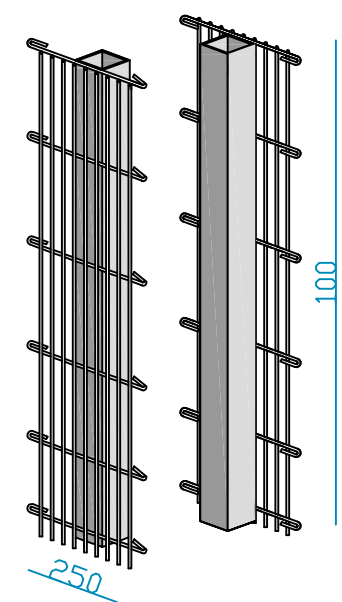

PATENTED

FLOOR - BOTTOM PANELS COVER PANELS

mod. B  red coloured
mod. C

NOT SURMOUNTABLE model

cod. B1/1

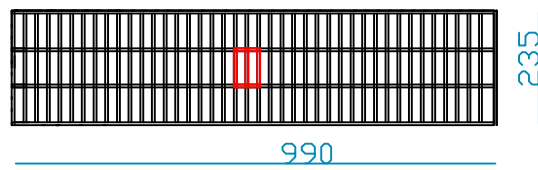

cod. C1/1

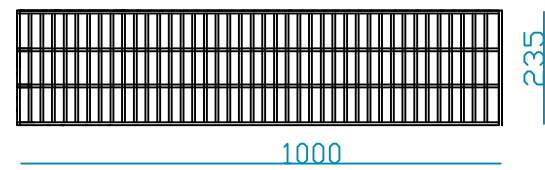

DESCRIPTION:

single wire
zinc-aluminum alloy
diameter 6 mm
mesh 19 x 200 mm

cod. B2/1

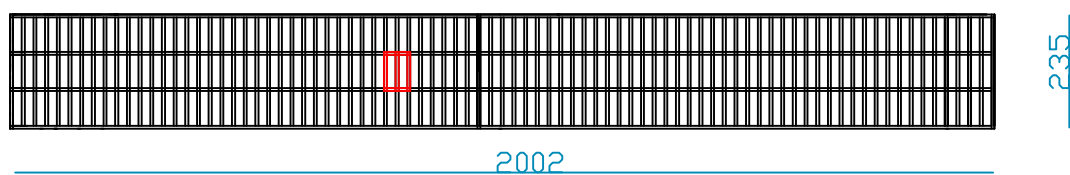

cod. C2/1

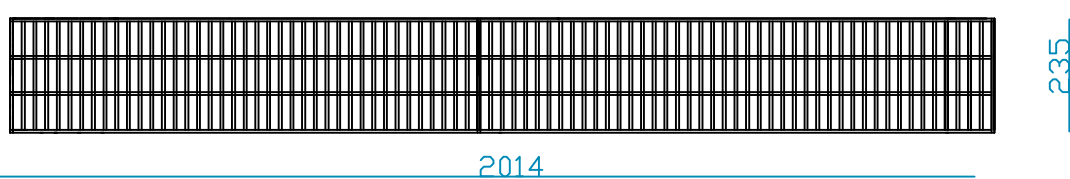

SURMOUNTABLE model

cod. B1/2

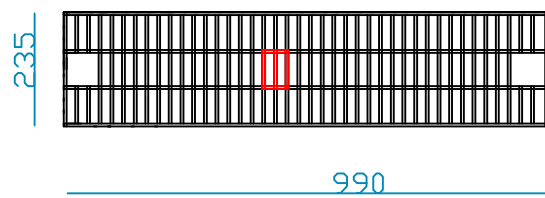

cod. C1/2

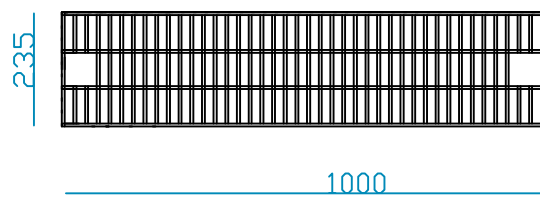

cod. B2/2

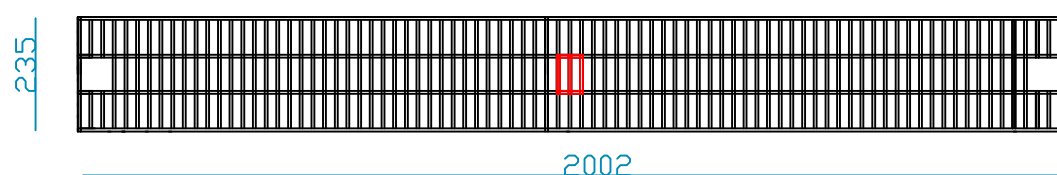

cod. C2/2

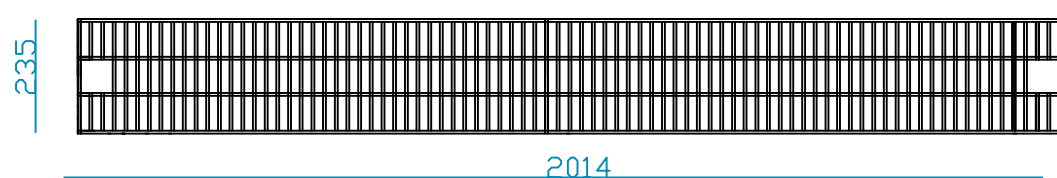

Detail

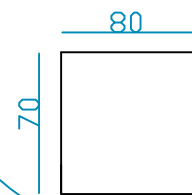

INTERNAL RODS

cod. QS

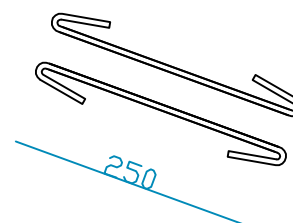

CLOSING RINGS



cod. AN

PATENTED

GIN
STEEL BOX®

MECCANURGICA
LEDRENSE
SOC.COOP.

ACCESSOIRES

FINAL CLOSING PANELS

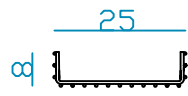
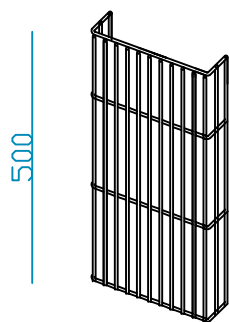

cod. CT.0.5

DESCRIPTION:

single wire
zinc-aluminum alloy
diameter 6 mm
mesh 19 x 200 mm

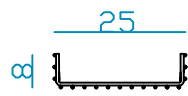
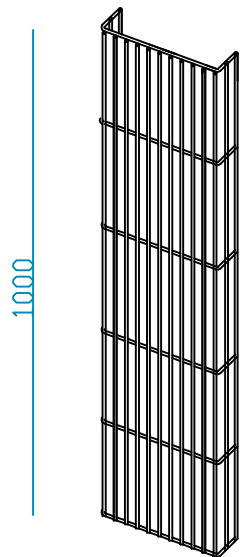

cod. CT.1

LIFTING SYSTEM - GJM COMB

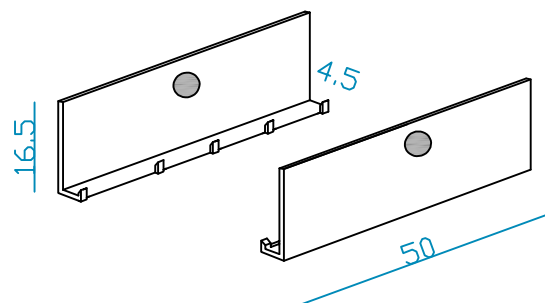

cod. PS

peso massimo 400 Kg/pc

PATENTED

PYLON

cod. IDS50

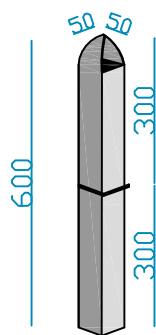

cod. IDS100

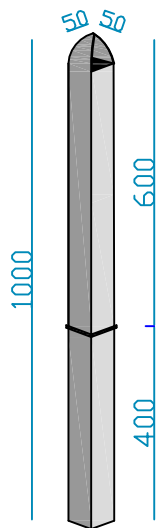

DESCRIPTION:

galvanized pylon 50 x 50 thickness 3 mm

DESCRIPTION:

double pylon galvanized, outdistanced for 32 mm

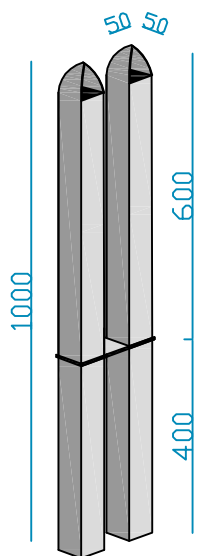

cod. IDD100

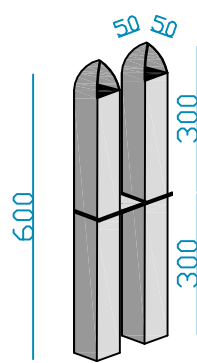

cod. IDD 50

DESCRIPTION:

galvanized pylon 50 x 50 thickness 3 mm

anchor plate thickness 6 mm
holes Ø 12 x 22 mm

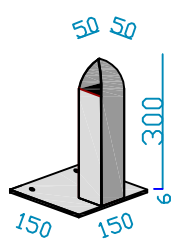

cod. ISP50

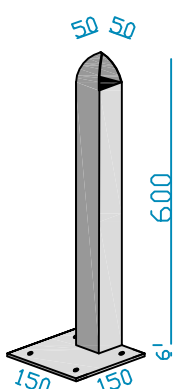

cod. ISP100

DESCRIPTION:

double pylon galvanized, outdistanced for 32 mm

anchor plate thickness 6 mm
holes Ø 12 x 22 mm

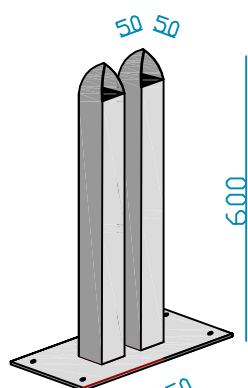

cod. IDP100

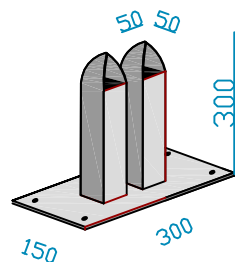

cod. IDP50

Anchoring: mechanical block type W-FAZ / S M10 Wuerth or M10 threaded bar class 8.8 with WIT-WM200 Wuerth resin

ALIGNMENT AND LOCKING CAP

cod. TA

DESCRIPTION: double pylon galvanized 50 x 50 x sp.3 mm outdistanced for 32 mm, h.100 mm with plate 50 x 132 x sp. 6 mm

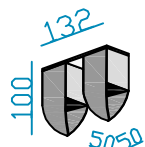

MEASUREMENT FOR THE PYLONS' POSITIONING

100 cm LENGTH VERSION

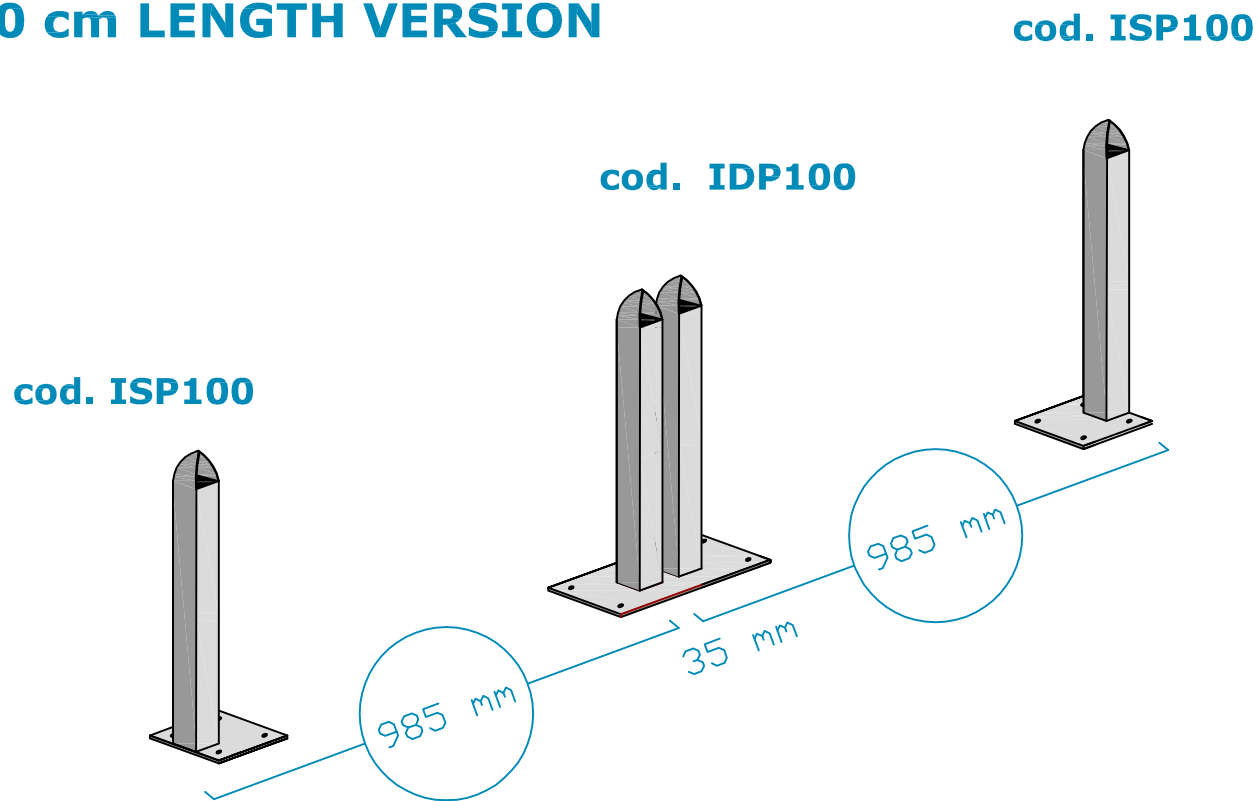

200 cm LENGTH VERSION

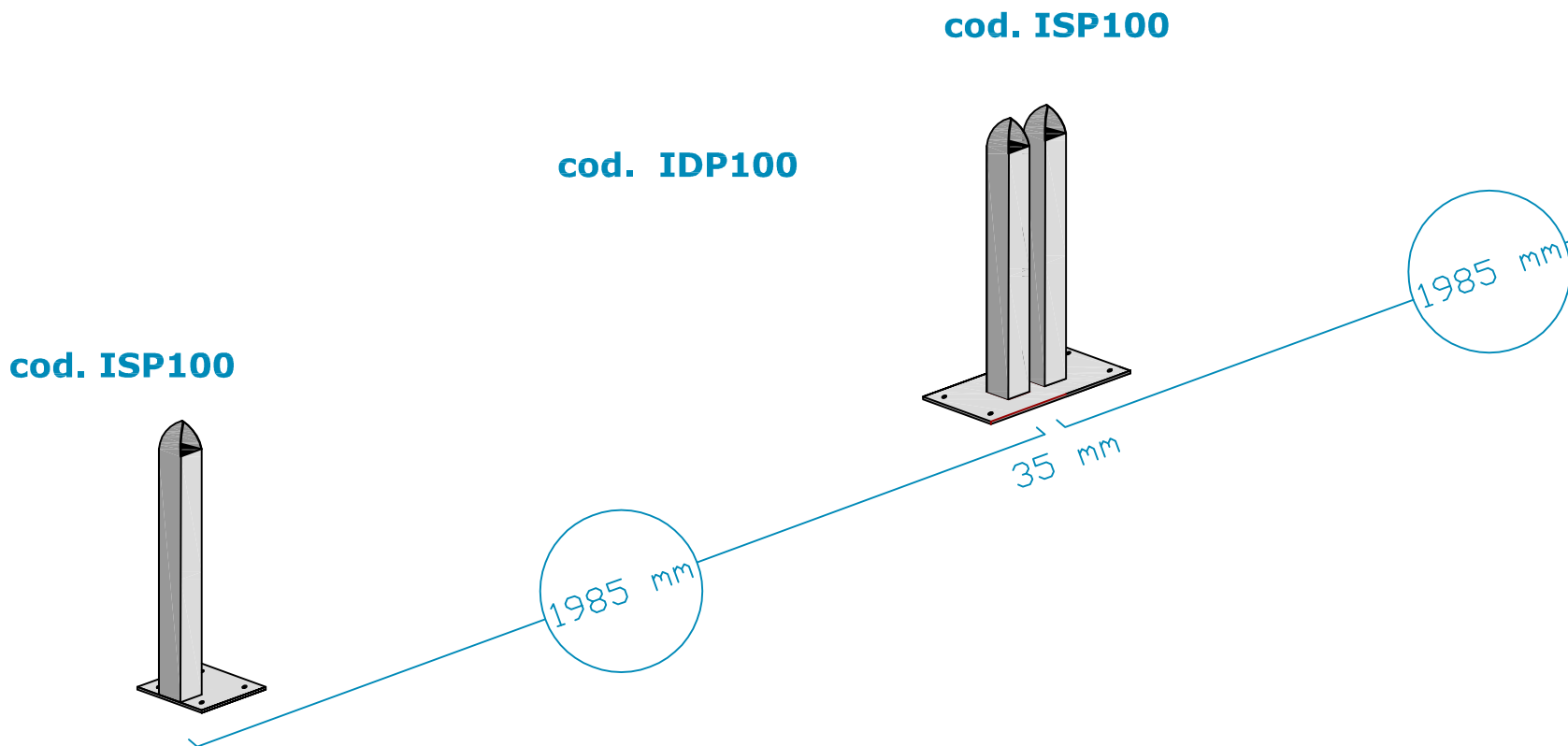

HEIGHT VERSION 50 cm

GJM 1.05.1

100 x 25 x 50 cm

INVENTORY OF COMPONENTS

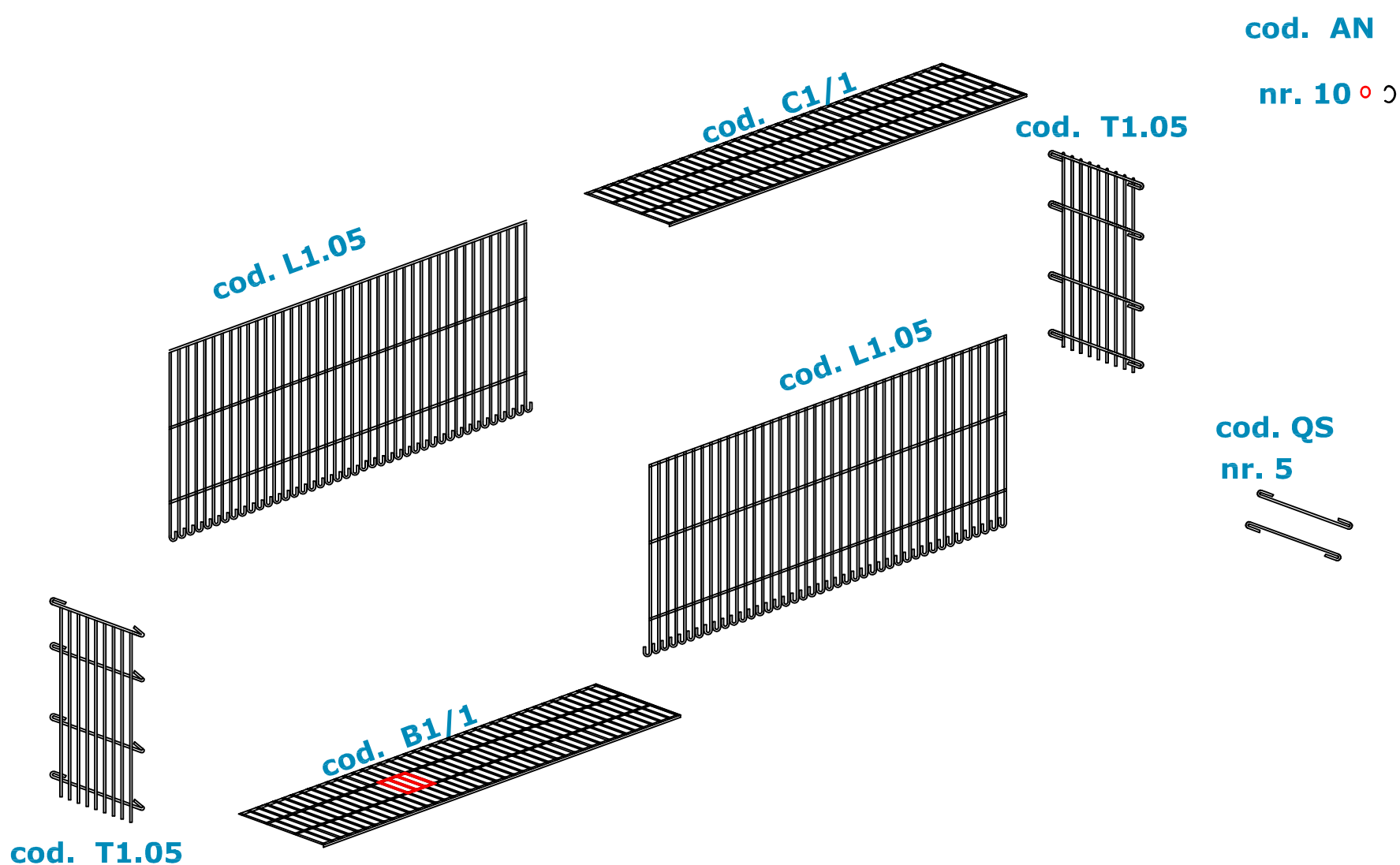

SUMMARY :

cod. L1.05	nr. 2
cod. B1/1	nr. 1
cod. C1/1	nr. 1
cod. T1.05	nr. 2
cod. QS	nr. 5
cod. AN	nr. 10

EMPTY WEIGHT
Kg. 18

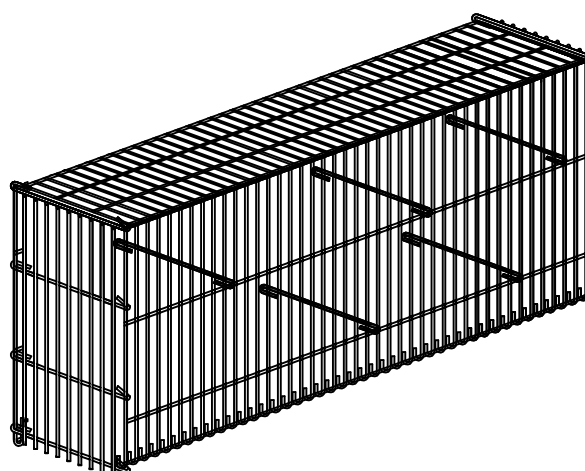

GJM
STEEL BOX®

MECCANURGICA
LEDRENSE
SOC.COOP.

HEIGHT VERSION 50 cm

GJM 2.05.1

200 x 25 x 50 cm

INVENTORY OF COMPONENTS

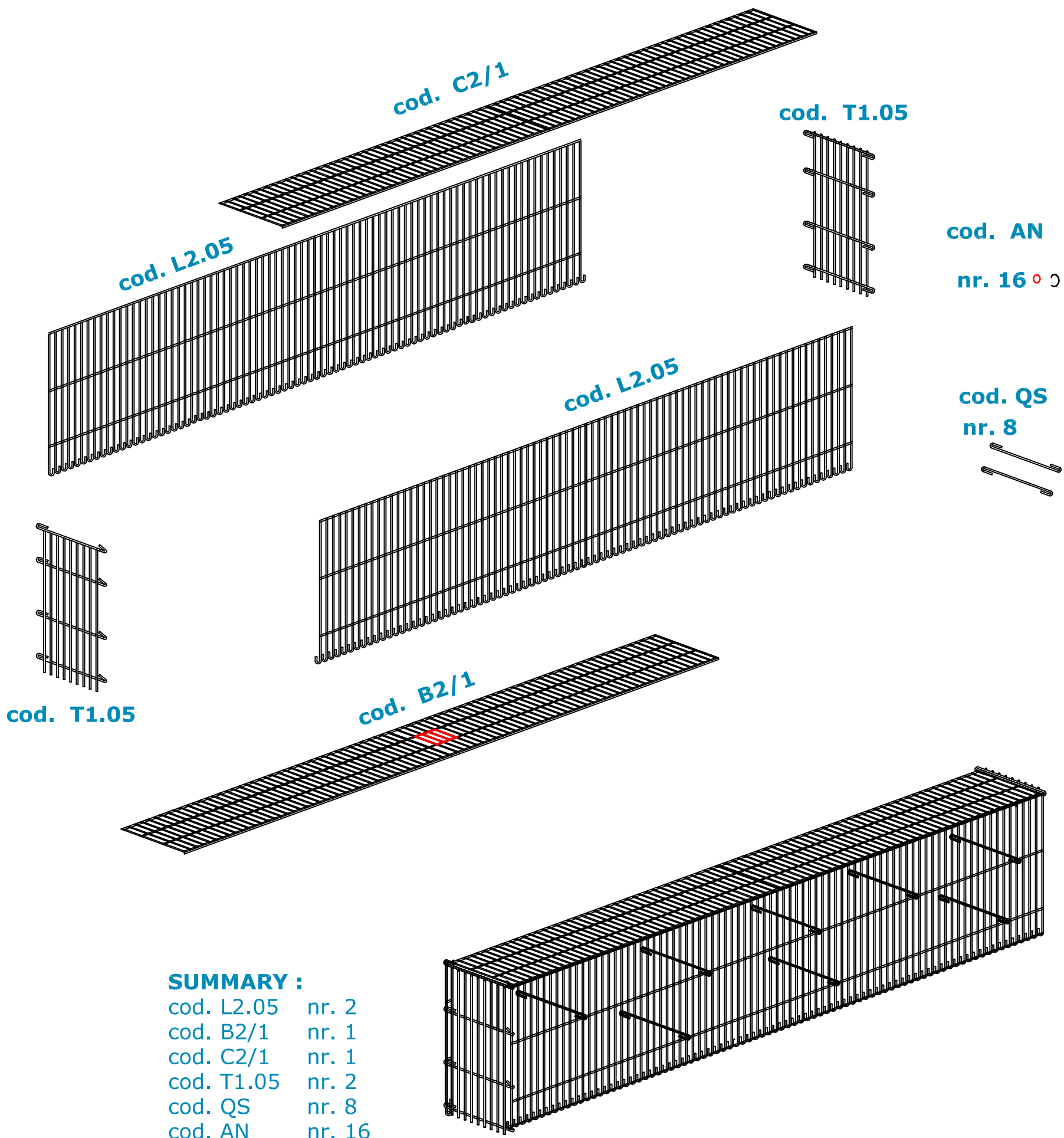

SUMMARY :

cod. L2.05	nr. 2
cod. B2/1	nr. 1
cod. C2/1	nr. 1
cod. T1.05	nr. 2
cod. QS	nr. 8
cod. AN	nr. 16

EMPTY WEIGHT
Kg. 36

rev. 2021

PATENTED

GJM
STEEL BOX®

MECCANURGICA
LEDRENSE
Soc.coop.

HEIGHT VERSION 50 cm

GJM 1.05.2

100 x 25 x 50 cm

INVENTORY OF COMPONENTS

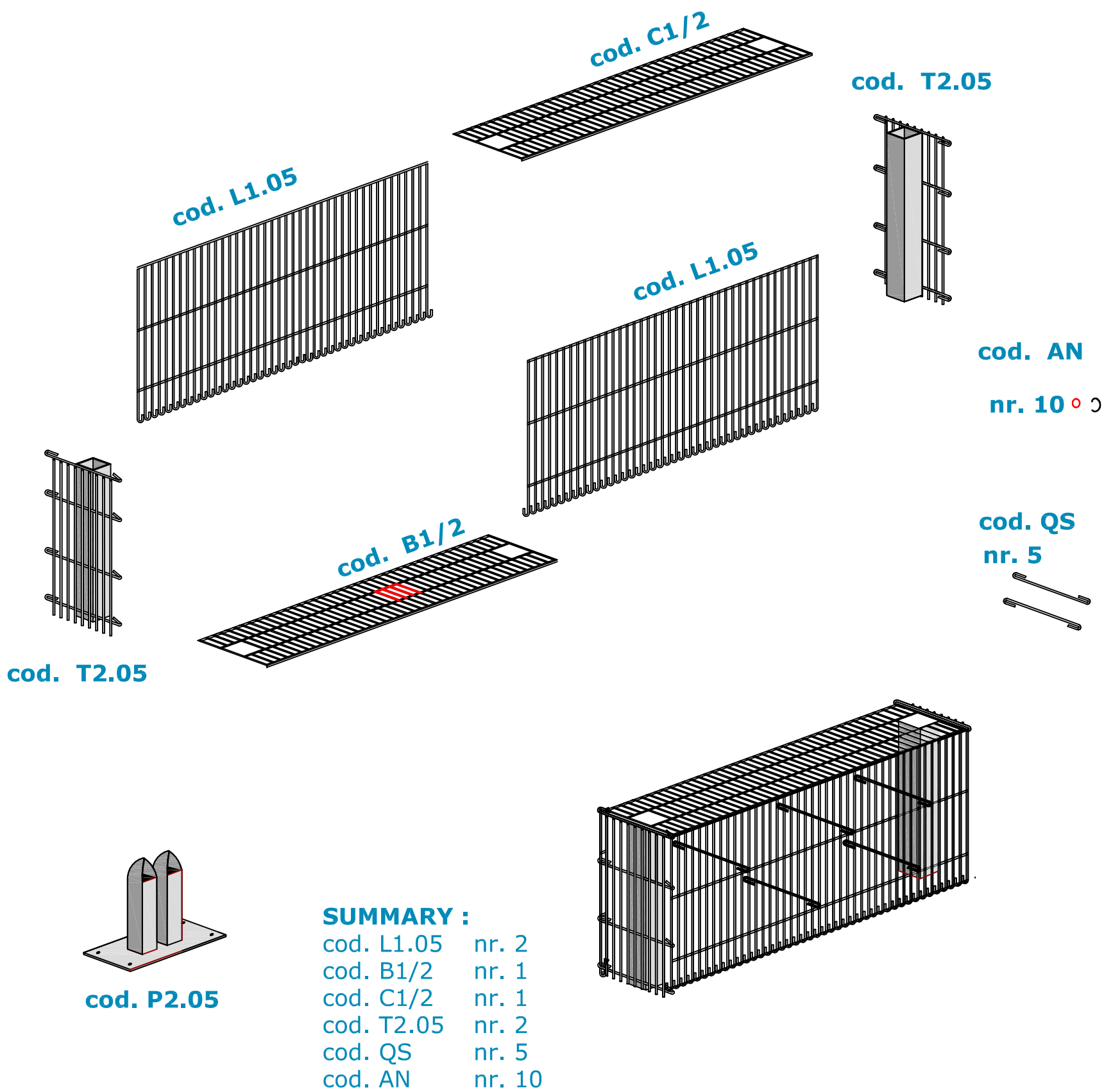

EMPTY WEIGHT
Kg. 22

GJM
STEEL BOX®

MECCANURGICA
LEDRENSE
SOC.COOP.

PATENTED

HEIGHT VERSION 50 cm

GJM 2.05.2

200 x 25 x 50 cm

INVENTORY OF COMPONENTS

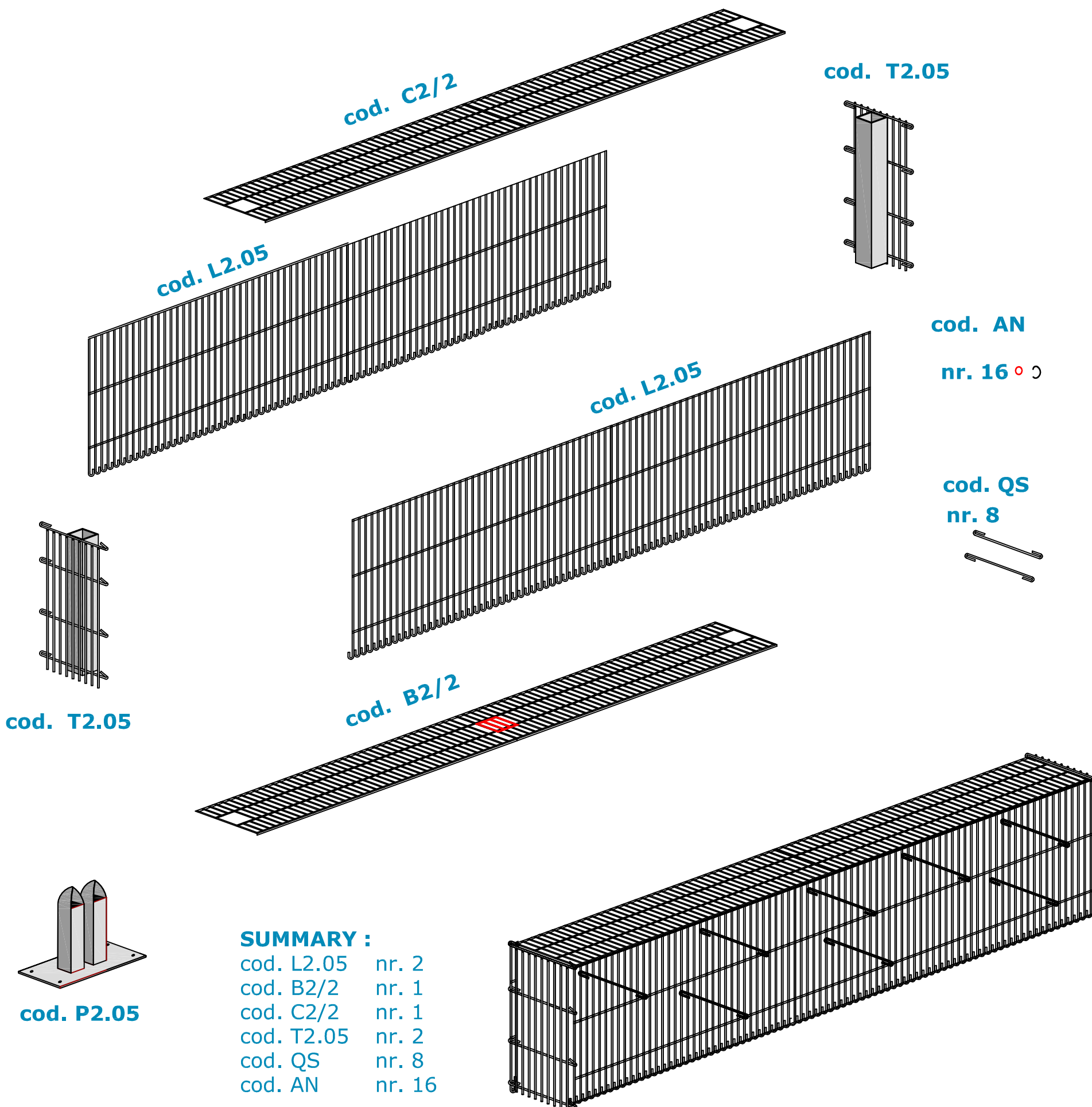

SUMMARY :

cod. L2.05	nr. 2
cod. B2/2	nr. 1
cod. C2/2	nr. 1
cod. T2.05	nr. 2
cod. QS	nr. 8
cod. AN	nr. 16

EMPTY WEIGHT
Kg. 40

PATENTED

HEIGHT VERSION 100 cm

GJM 1.1

100 x 100 x 25 cm

INVENTORY OF COMPONENTS

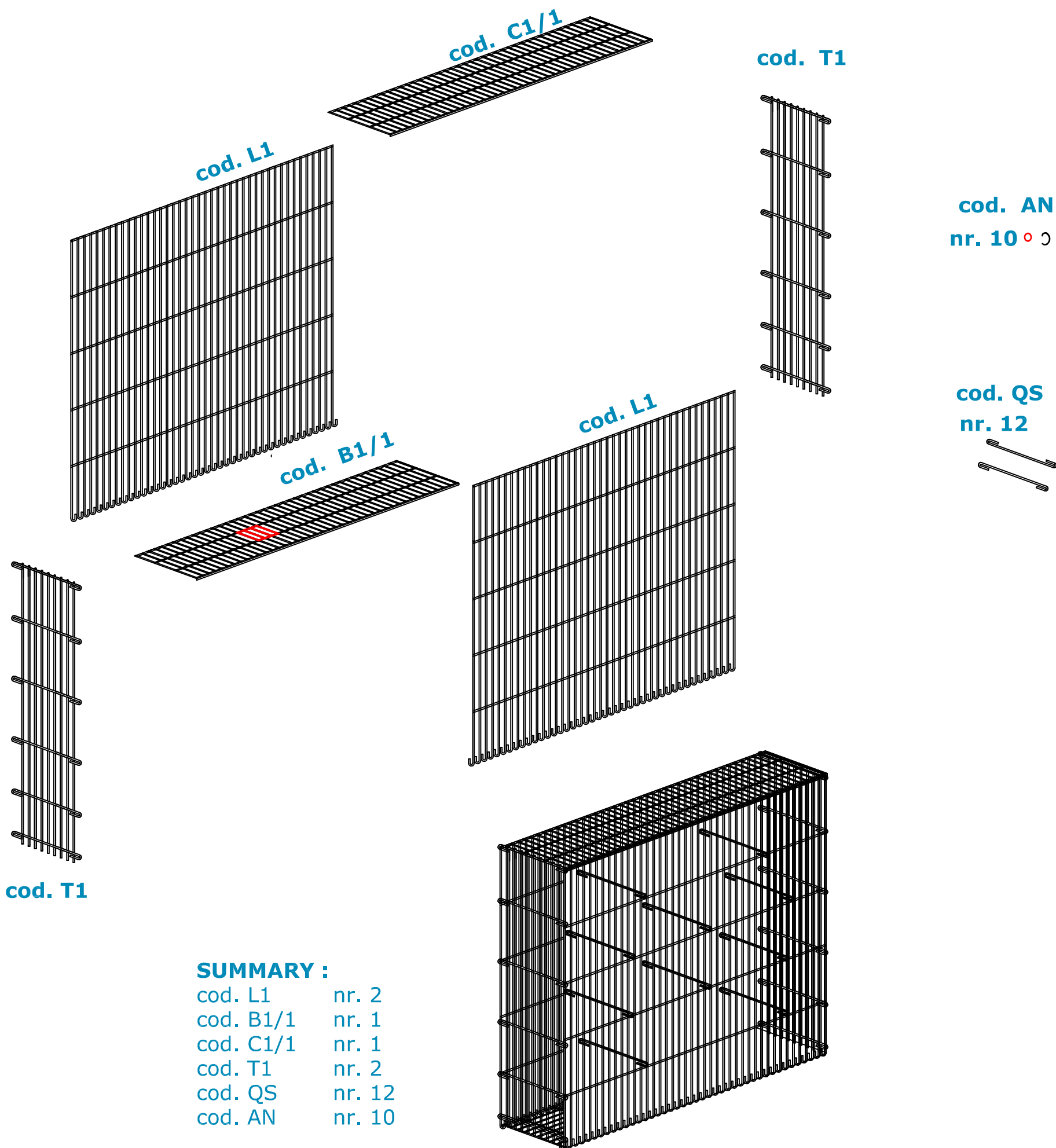

HEIGHT VERSION 100 cm

GJM 1.2

100 x 25 x 100 cm

INVENTORY OF COMPONENTS

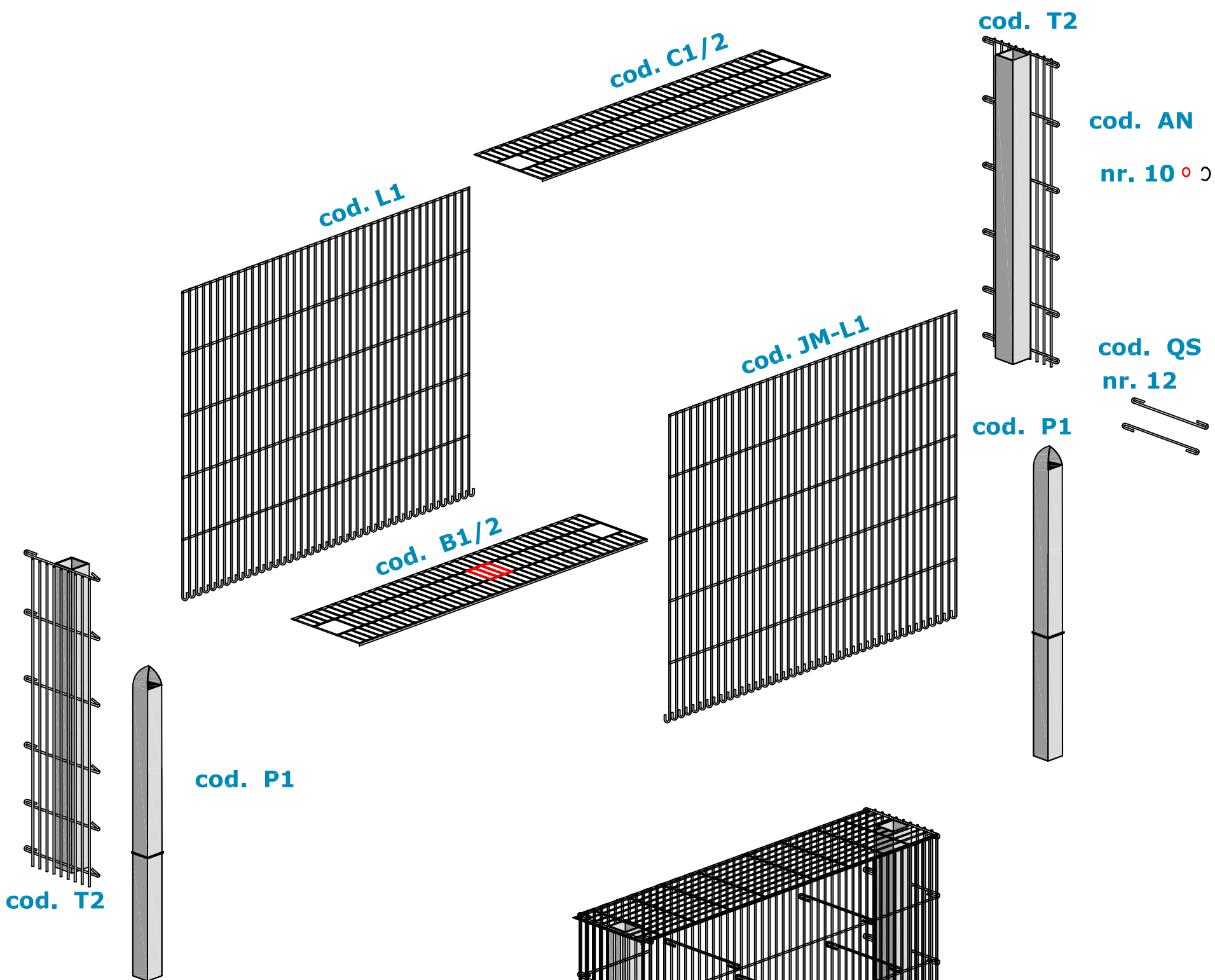

SUMMARY :

cod. L1	nr. 2
cod. B1/2	nr. 1
cod. C1/2	nr. 1
cod. T2	nr. 2
cod. QS	nr. 12
cod. AN	nr. 10

EMPTY WEIGHT
Kg. 44

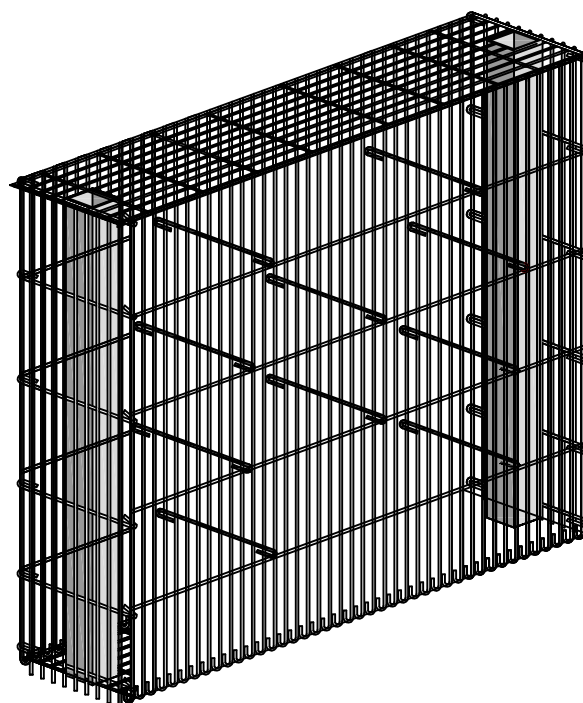

GJM
STEEL BOX[®]

MECCANURGICA
LEDRENSE
SOC.COOP.

PATENTED

HEIGHT VERSION 100 cm

GJM 2.1

200 x 25 x 100 cm

INVENTORY OF COMPONENTS

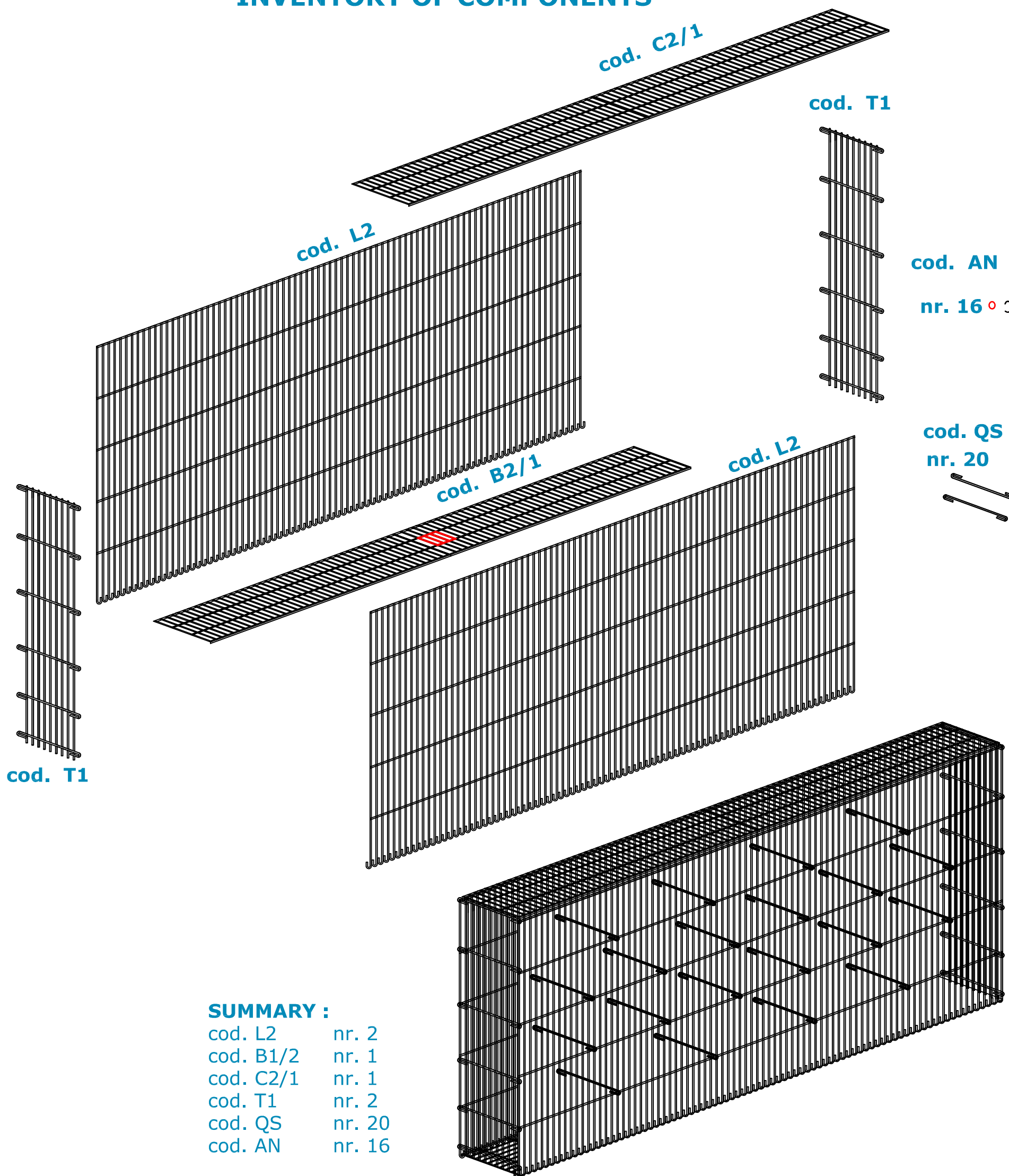

SUMMARY :

cod. L2	nr. 2
cod. B1/2	nr. 1
cod. C2/1	nr. 1
cod. T1	nr. 2
cod. QS	nr. 20
cod. AN	nr. 16

EMPTY WEIGHT
Kg. 62

PATENTED

HEIGHT VERSION 100 cm

GJM 2.2

200 x 25 x 100 cm

INVENTORY OF COMPONENTS

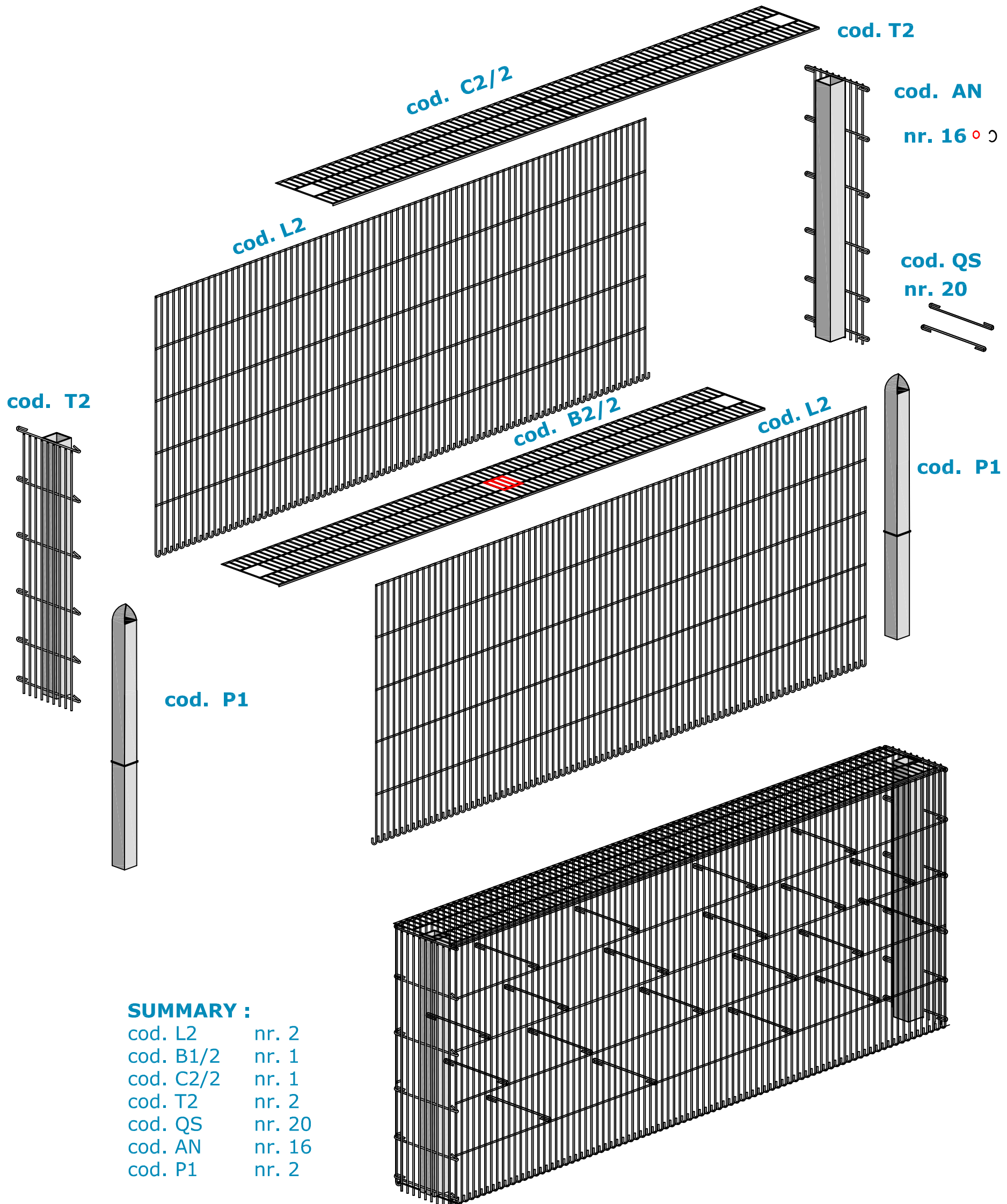

GJM STEEL BOX®

**MECCANURGICA
LEDRENSE**

SOC.COOP.